

	Document Title		
	<b>Investigational ClearPlasma Device- Instruction for Use</b>		
	Document No.	Revision	Page
	QD-06-024	03	1 of 11

Approval				Controlled document
	Title	Name	Signature	Date
Issued By:	QA Manager	Nadia Fiks		16-Jul-2023
Reviewed By:	Operations Manager	Samah Waked		16-Jul-2023
Approved By:	CEO	Zeev Dvashi		16-Jul-2023
Effective Date:				16-Jul-2023

Revision History		
Rev. #	Date	Description
01	08-Jul-2022	New document
02	28-Feb-2023	DCCR-011-2023
03	16-Jul-2023	DCCR-035-2023

Distribution List		
Copy #	Position	Department
1	CEO	Management
2	Operations Manager	Manufacturing
3	QA Manager	QA

This document contains proprietary information which is the sole property of PLAS-FREE Ltd. The document is intended for the recipient only. By receiving this document, the recipient undertakes not to copy or disclose the document in whole or any part of it without the prior written permission of PLAS-FREE Ltd.

## 1. Device Description

- 1.1. ClearPlasma is a single-use sterile extracorporeal plasma absorber intended for removal of Plasminogen from donor's plasma.

The body of the absorber is a plastic housing with three principal compartments – inlet, resin compartment (Body) and outlet. The compartments are divided by two membranes, which define the resin compartment's limits (refer to Figure 1).

ClearPlasma is equipped with two connecting lines. These connecting lines are connected to ClearPlasma device by means of ISO 80369-7 Luer connectors. The distal ends of the connecting lines are also equipped with ISO 80369-7 Luer connectors and caps, in order to allow connection with standard commercially available sterile bloodlines/infusion set/system and prevent tube contamination (refer to Figure 2).

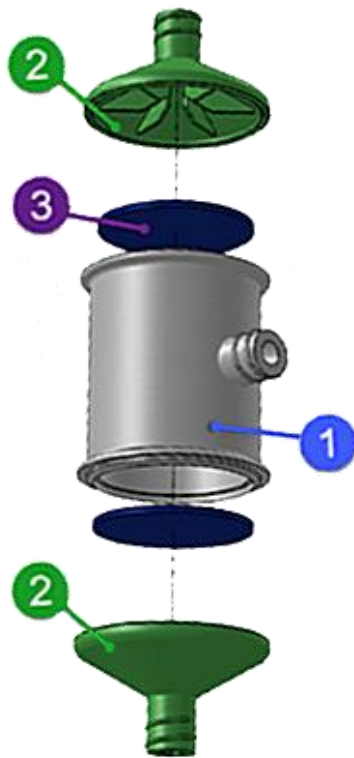

Figure 1. ClearPlasma device:  
(1) Body, (2) Endcaps, (3) Membrane

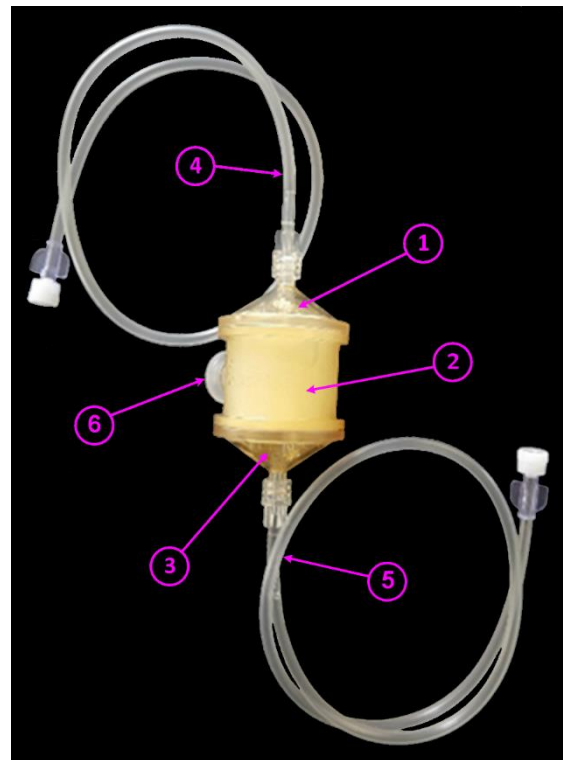

Figure 2. ClearPlasma device and its components  
- as provided to the user:

- (1) Inlet Cap, (2) Body, (3) Outlet Cap, (4) Inlet Connecting Line, (5) Outlet Connecting Line, (6) Silicone Plug

- 1.2. ClearPlasma housing has an embossed arrow and the corresponding marking "THIS SIDE DOWN" that indicate the correct connection orientation in respect to the patient's vein access (in case of bedside use) or collecting plasma bag (in case of Blood bank use) - refer to Figure 3. The device name and the company name are also impressed on the device housing (refer to Figure 4). When ClearPlasma device is connected in the correct orientation, the inscriptions are red normally and not upside down.

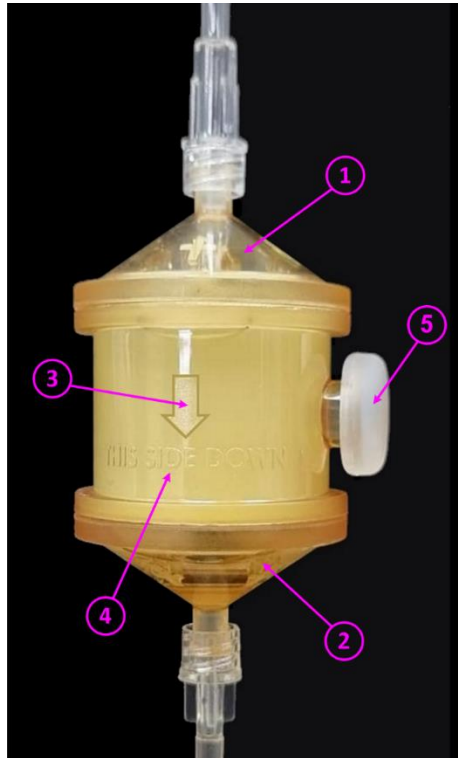

Figure 3: Flow direction marked on PlasFree device:

- (1) Inlet, (2) Outlet, (3) Flow direction arrow, (4) “THIS SIDE DOWN” marking, (5) Silicone Plug



Figure 4: Company name and Device name

1.3. ClearPlasma medical device does not contain medicinal products, is not produced using animal tissues, does not incorporate either human blood or plasma derivatives and is not manufactured utilizing either non-viable tissues or cells of human origin nor their derivatives.

1.4. ClearPlasma is supplied sterile (gamma radiation sterilization) and pre-filled with agarose beads (the resin) and saline solution (refer to §15 for details on device contact materials).

1.5. Device accessories.

1.5.1. Upper-side bloodline.

a. For bedside use:

Sterile commercially available bloodline / infusion set / system equipped with flow regulator or drip chamber or roller clamp, spike connector and ISO 80369-7 Luer connector.

b. For blood bank use:

Sterile commercially available bloodline / infusion set / system equipped with flow regulator or drip chamber or roller clamp and either a spike connector and ISO 80369-7 Luer connector or two ISO 80369-7 Luer connectors.

1.5.2. Lower-side bloodline.

a. For bedside use:

	Document Title		
	<b>Investigational ClearPlasma Device- Instruction for Use</b>		
	Document No.	Revision	Page
	<b>QD-06-024</b>	<b>03</b>	<b>4 of 11</b>

Sterile commercially available bloodline / infusion set / system equipped with flow regulator or drip chamber or roller clamp and two ISO 80369-7 Luer connectors.

b. For blood bank use:

- Sterile commercially available bloodline / infusion set / system equipped with flow regulator or drip chamber or roller clamp and two ISO 80369-7 Luer connectors.
- Sterile commercially available collection bag either equipped with ISO 80369-7 Luer connector or intended for connection using a dedicated Sterile Connecting Device.

1.5.3. The above-mentioned device accessories are not part of ClearPlasma device and are not supplied with ClearPlasma.

## 2. Intended Use

ClearPlasma is intended for removal of plasminogen from donor's plasma.

## 3. Intended Users

ClearPlasma device is intended for professional use only. ClearPlasma should only be used by medical personnel who have been properly trained in administration of extracorporeal therapies.

## 4. Use environments

ClearPlasma is intended to be used:

- in blood banks, when used connected to a collecting plasma bag, and
- in healthcare settings, when used connected to a patient's vein access in bedside configuration.

## 5. Indications

- 5.1. ClearPlasma is indicated only for treating plasma and not for other blood components.
- 5.2. ClearPlasma is indicated for treating of massive bleeding.
- 5.3. ClearPlasma is intended to be used on patients of 18 years old and older.

## 6. Contraindications

Do not use ClearPlasma if any of the following occur:

- 6.1. Risk of blood clotting.
- 6.2. Fluid accumulation in the brain.
- 6.3. Retinal thrombosis.
- 6.4. Experiencing a heart attack.
- 6.5. Maternity or breastfeeding - safety has not been established.
- 6.6. Patient is younger than 18 years (safety has not been established).
- 6.7. Patient with history of allergies to any of the device contact materials (refer to §15).

## 7. Warnings

- 7.1. Do not use ClearPlasma if it appears to be damaged.

7.2. Do not use ClearPlasma if the resin compartment is not completely filled (refer to Figure 5).



**Correct** - the resin compartment (Body) is completely filled with non-transparent solution



**Incorrect** - the resin compartment (Body) is not completely filled with non-transparent solution

Figure 5

7.3. Do not use ClearPlasma if agarose beads appear to be free-floating within the endcaps (refer to Figure 6 and Figure 7).

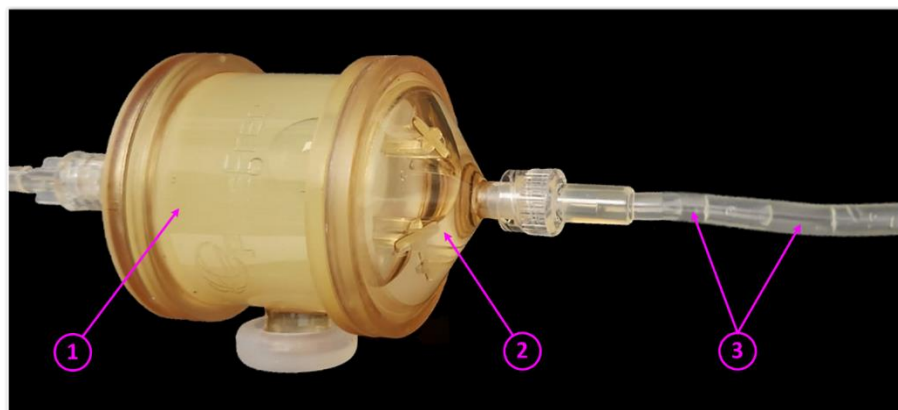

**Correct:**

- (1) The resin compartment (Body) is completely filled with non-transparent solution;
- (2) Clear liquid may appear inside the Inlet/Outlet Cap;
- (3) Clear liquid may appear in the Inlet/Outlet Connecting Line;
- (4) Silicone Plug is fixed in place and not damaged.

Figure 6

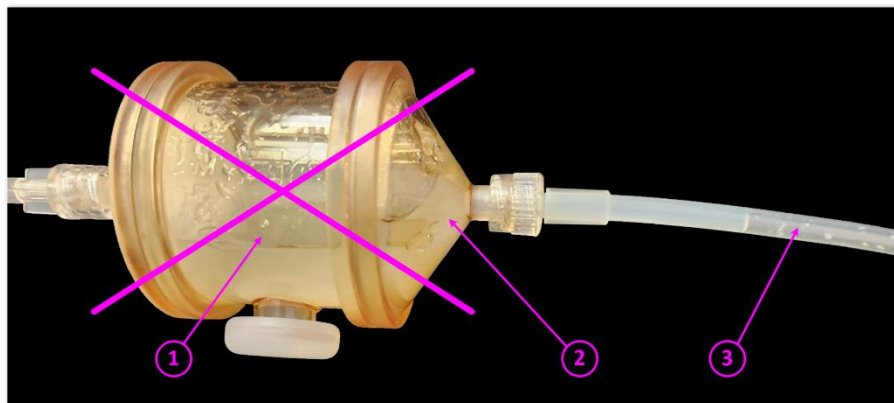
**Incorrect:**

- (1) The resin compartment (Body) is not completely filled with non-transparent solution; or
- (2) Non-transparent solution appears inside the Inlet/Outlet Cap; or
- (3) Non-transparent solution containing resin beads appears in the Inlet/Outlet Connecting Line;

Figure 7

- 7.4. Do not use ClearPlasma if the Silicone Plug is removed or damaged.
- 7.5. **ClearPlasma is a single use device.** Reuse of ClearPlasma may result in secondary infection, device clotting and/or a biohazardous situation. Multiple use of ClearPlasma is strictly prohibited.
- 7.6. Do not use the device if package is damaged or opened.
- 7.7. Keep away from direct sunlight or heat.
- 7.8. Use ClearPlasma device only with standard commercially available sterile bloodlines/infusion set/system equipped with Luer connectors compliant with ISO 80369-7.

**8. Precautions**

- 8.1. ClearPlasma device is supplied sterile inside a protective pouch. Carefully remove ClearPlasma from the pouch and examine for visible defects or damage.
- 8.2. Silicone Plug is tightly fixed on the device and is intended for device sealing. Removing the plug is prohibited. Take care not to remove or damage the Silicone Plug during device usage.
- 8.3. During the treatment the extracorporeal circuit should be monitored continuously for plasma leaks. In the event of a plasma leak during the treatment, the healthcare provider should respond according to the facility's established protocols.
- 8.4. Avoid the entry of air into ClearPlasma. Air entering the extracorporeal circuit during treatment can result in serious patient injury or death. Check the integrity of all bloodlines and connections prior to the initiation of the treatment and periodically during the treatment as part of the clinical practice.
- 8.5. **ClearPlasma should only be used as directed by a physician and** according to the IFU.
- 8.6. The pressure in the Upper-side bloodline should be monitored according to acceptable clinical practice to avoid abnormal pressure.



	Document Title		
	<b>Investigational ClearPlasma Device- Instruction for Use</b>		
	Document No.	Revision	Page
	<b>QD-06-024</b>	<b>03</b>	<b>7 of 11</b>

## 9. Side Effects

### Allergic Reactions:

Some patients may develop allergic reactions to plasma received during a transfusion, even when the plasma of the compatible blood type is used. In such cases, symptoms may include rash and fever. In any event of allergic reaction, a physician should be consulted.

## 10. Limitations

- 10.1. **ClearPlasma** device should be stored within the temperature range of 2°C to 8°C and used within the temperature range of 2°C to 30°C.
- 10.2. Storing condition of Plasminogen Depleted Plasma (PDP) generated by ClearPlasma
  - 10.2.1. If the Plasminogen Depleted Plasma (PDP) was generated directly from fresh donor plasma, the PDP can be frozen and stored for up to 2 years before use at a temperature of -25°C or lower and according to the standard blood-bank protocol of the local competent authority.
  - 10.2.2. If the Plasminogen Depleted Plasma (PDP) was generated from thawed plasma, the PDP can be stored before use for not more than 5 days at 2°C to 8°C and according to the standard blood-bank protocol of the local competent authority.

## 11. Foreseeable risks

- 11.1. Use of ClearPlasma device that has leaked (resin compartment is not completely filled with resin) reducing the efficacy of the device.
- 11.2. Removing or damaging the Silicone Plug may result in reduced device efficacy and patient infection.
- 11.3. Incorrect direction of device connection prevents normal ClearPlasma operation.
- 11.4. Non-sterile connections: user does not connect properly the bloodline tubes to ClearPlasma device enabling bacteria and/or virus penetration into the blood lines and, possibly, patient infection.
- 11.5. Plasma leakage during filtration: user does not connect properly the bloodline tubes to ClearPlasma device, reducing the efficacy of ClearPlasma treatment and may cause patient infection.
- 11.6. Improper device handling: user damages the device while opening the packaging.
- 11.7. Reuse or re-sterilization of the device: user re-uses or re-processes the device possibly causing patient injury.
- 11.8. Use of inappropriate flow regulators/tubes or damaged tubes: improper plasma flow causing reduced device efficacy.
- 11.9. Use of inappropriate bloodlines/infusion set/system not complying with device requirements: the device cannot be properly connected resulting in ineffective treatment.
- 11.10. Misconnection to IV line: the device cannot be connected properly resulting in plasma leakage during filtration and ineffective treatment.
- 11.11. Improper use of ClearPlasma: user attempts to use the device when the filtration time for 250 mL plasma bag is less than 30 min (causing reduction of ClearPlasma efficiency to absorb plasminogen) or more than 60 min (causing low transfusion rate delaying plasma effect in bleeding patients).

	Document Title		
	<b>Investigational ClearPlasma Device- Instruction for Use</b>		
	Document No.	Revision	Page
	<b>QD-06-024</b>	<b>03</b>	<b>8 of 11</b>

## 12. Instructions for use

- 12.1. ClearPlasma device should be placed at room temperature for about 20 min before use (refer to §10 for details).
- 12.2. Device Setting.
  - 12.2.1. **Carefully remove ClearPlasma from the pouch and examine for defects or damage. Replace ClearPlasma device if defective or damaged. Verify that the Upper-side and the Lower-side** bloodlines are suitable for use with ClearPlasma and are not defective or damaged. Replace defective or damaged accessories.
  - 12.2.2. Hang the plasma bag on an IV pole or a hanging hook.
  - 12.2.3. Make sure that the clamp available on the Upper-side bloodline is closed and connect the Upper-side bloodline to the plasma bag as detailed below:
    - a. For bedside use - by means of a spike connector.
    - b. For blood-bank use - by means of a spike connector or an ISO 80369-7 Luer connector or a dedicated Sterile Connecting Device.
  - 12.2.4. Connect the ISO 80369-7 Luer connector of the Upper-side bloodline to the mating Luer connector of the inlet connecting line of ClearPlasma, taking care of proper device orientation (refer to § 1.1).
  - 12.2.5. Make sure that the clamp available on the Lower-side bloodline is closed and connect the ISO 80369-7 Luer connector of the outlet connecting line of ClearPlasma to a mating Luer connector of Lower-side bloodline.
  - 12.2.6. **Set the flow regulator available on the Upper-side bloodline for an appropriate flow rate, so that the filtration** time for 250 ml plasma bag is not less than 30 min and not more than 60 min.
  - 12.2.7. Open all available clamps and perform priming by allowing the plasma flow through the device and drizzle outside the Lower-side bloodline into an appropriate container for few seconds, as per regular procedures in the hospital/blood bank setting, avoiding user/patient/device contamination. Ensure that all air has been removed from the bloodlines.
  - 12.2.8. Once the priming is completed, close the clamp available on the Lower-side bloodline.
  - 12.2.9. Check all bloodlines' connections for absence of fluid leak or air entrance.
  - 12.2.10. Connect the ISO 80369-7 Luer connector of the Lower-side bloodline as detailed below:
    - a. For bedside use - to a mating Luer connector of the patient vein-access.
    - b. For blood-bank use - to a plasma collecting bag by means or an ISO 80369-7 Luer connector or a dedicated Sterile Connecting Device.
  - 12.2.11. Open the clamp available in the Lower-side bloodline and proceed with plasma filtration.
  - 12.2.12. When the filtration process is completed, follow the instructions for use of the Lower-side bloodline for disconnecting from patient vein access or plasma collection bag. Do not disconnect ClearPlasma from any bloodline. Discard ClearPlasma together with the connected bloodlines in an appropriate biohazard waste receptacle and according to current regulations.



	Document Title		
	<b>Investigational ClearPlasma Device- Instruction for Use</b>		
	Document No.	Revision	Page
	<b>QD-06-024</b>	<b>03</b>	<b>9 of 11</b>

### 13. Instructions for use during treatment

- 13.1. Check that the arrow embossed on ClearPlasma housing is pointing toward the floor during the entire filtration procedure.
- 13.2. Monitor the pressure in the extracorporeal circuit, including the line between the plasma bag and ClearPlasma. Investigate any indication of abnormal pressure.
- 13.3. Visually inspect ClearPlasma device for any signs of clotting or plasma leaks from the circuit. Report the occurrence of clotting or plasma leaks to the responsible medical professional.
- 13.4. Periodically monitor the extracorporeal circuit for evidence of obstruction, security of fittings, and air presence within the circuit.

### 14. Performance Characteristics

- 14.1. The plasma flow occurs by gravity feed only.
- 14.2. Plasma filtering capacity volume: up to 250 mL.
- 14.3. Flow resistance ( $Q_b < 500 \text{ mL/min}$ ): 300 mmHg.
- 14.4. Storage fluid: Saline solution.
- 14.5. Sterilization method: Gamma Radiation.
- 14.6. Acceptable plasma filtration time for 250 mL plasma bag: not less than 30 min and not more than 60 min.
- 14.7. Pressure resistance of final device: the device is capable of sustaining up to 330 kPa positive air pressure.

### 15. Device Contact Materials

Device Part	Raw Materials
<b>Resin</b>	Agarose beads
<b>Saline</b>	Sodium Chloride 0.9% W/V
<b>Filter housing</b>	<b>BODY and CAP:</b> Biocompatible Polycarbonate (PC) <b>PLUG:</b> Silicone 80 Shore A
<b>Membrane</b>	Hydrophilic Polyethersulfone (PES)
<b>Connecting line M/F 50cm</b>	<b>PRESSURE MONITORING LINE:</b> PVC AM 83 00+TOTM <b>FEMALE CONNECTOR LL (ID 4.0 ±0.1 MM):</b> ABS Terluc 2802 HD <b>MALE CONNECTOR 4.1 (ID 4.0 ±0.1 MM):</b> ABS Terluc 2802 HD <b>CAP FOR MALE, VENTED:</b> PE ERACLENE MP90 U <b>CAP FOR FEMALE, VENTED:</b> ABS Terluran GP35

### 16. Serious incident reporting

Any serious incident that has occurred in relation to the device should be reported to the PLAS-FREE responsible person and to the competent authority of the Member State in which the user and/or patient is established.

	Document Title		
	<b>Investigational ClearPlasma Device- Instruction for Use</b>		
	Document No.	Revision	Page
	<b>QD-06-024</b>	<b>03</b>	<b>10 of 11</b>











### 17. Authorized Representative in the European community/European Union

MedNet EC-REP Iib GmbH  
Borkstrasse 10  
48163 Münster, Germany

### 18. Legal Manufacturer

Manufacturer: PLAS-FREE Ltd  
Reg. Number: 515684009  
Wadi El Haj 13, Nazareth, Israel  
ZIP 17111; P.O. box 1252  
Tel: +972-4-609-8615 Fax: +972-4-656-4129  
Email: [info@plas-free.com](mailto:info@plas-free.com)

### 19. List of symbols on the ClearPlasma labeling

#	Symbol	Description
19.1.		Medical device
19.2.		Catalogue number
19.3.		Batch code
19.4.		Serial number
19.5.		Country of manufacture (Note: with a date of manufacture)
19.6.		Use-by date
19.7.		Do not re-use
19.8.		Non-pyrogenic
19.9.		Sterilized using irradiation (Note: By Gamma radiation)
19.10.	 <a href="https://www.plas-free.com/information-for-physicians">https://www.plas-free.com/information-for-physicians</a>	Consult instructions for use or consult electronic instructions for use. IFU will be published on manufacturer's website after CE mark granting.



Document Title <b>Investigational ClearPlasma Device- Instruction for Use</b>		
Document No. <b>QD-06-024</b>	Revision <b>03</b>	Page <b>11 of 11</b>

#	Symbol	Description
19.11.		Temperature limitation
19.12.		Manufacturer: PLAS-FREE Ltd Company# 515684009 Wadi El Haj 13, Nazareth, Israel. ZIP 17111; P.O. box 1252 Ph: +972-46098615, Fax: +972-46564129, Email: info@plas-free.com
19.13.		Authorized representative in the European community/European Union: MedNet, EC-REP I Ib GmbH, Borkstrasse 10, 48163 Münster, Germany
19.14.		Keep away from sunlight and heat
19.15.		Keep package dry and keep away from rain
19.16.		Do not use if package is damaged (or opened) and consult instructions for use
19.17.		Single sterile barrier system with protective packaging outside
19.18.		Product quantity: one unit (For Tyvek Label and Single Kit Carton Label)
19.19.	Intended use	Sterile absorber for removal of Plasminogen from plasma units
19.20.	Exclusively for clinical investigation	The device will be only used for clinical trials
19.21.		Product quantity: 16 units (For Cardboard box label)
19.22.		This Way up
19.23.		Fragile, Handle with care